

GREATER DANGER DEMANDS
GREATER RESPONSE.



Striker

6x6

Your world is ARFF. Your responsibility has reached an all-new extreme. You have to lead like never before. **The Striker changes everything.** Greater fire suppression, control, safety and versatility maximize your response like no other truck in the industry. The Striker arms you with the ultimate attack force, for the ultimate threats.

FOLLOW NO ONE.



FOLLOW NO ONE.

The Striker delivers innovative fire suppression, unmatched chassis performance, smart design and complete support. So you can take on ARFF hazards like never before.

Unmatched Chassis Performance

- Meets NFPA, ICAO & EU standards
- Oshkosh® patented TAK-4® all-wheel independent suspension
- Center steer for greater all-around visibility and control
- Rear steer dramatically reduces tire wear and improves turning radius

Innovative Fire Suppression

- Crosslays allow access to handlines from either side of truck
- Snozzle HRET available on all models

Smart Design

- Modular cab layout with switching and controls logically placed
- Spacious cab seats up to 5 firefighters
- Panoramic forward view
- Walk-in service ports with single-location filters
- Enormous storage compartments adapt to your needs
- Vehicle CAN based systems allow simple diagnostic support

Complete Support

- 24/7/365 support available
- Comprehensive parts/technical support at airportproductsupport.com
- Dedicated professional operators and maintenance training available

THE STRIKER CHANGES THE WAY YOU FIGHT BACK.



6x6



The Striker 6x6 meets or exceeds all National Fire Protection Association (NFPA) 414, Federal Aviation Administration (FAA) and International Civil Aviation Organization (ICAO) requirements for all 3,000 gallon (11356 l) water capacity ARFF vehicles.

PERFORMANCE

Top Speed: Greater than 70 mph (113 km/h)

Side Slope Stability (Static): $\geq 30^\circ$

Gradeability: Ascend/descend a 50% grade

Turning Diameter: 78 ft. (23.8 m)

Dimensions:

- Length – 475 in. (12 m)
- U.S. Width – 120 in. (305 cm)
- European Width – 118 in. (300 cm)
- Height without HRET – Less than or equal to 140 in. (356 cm) (with full water tank)

CHASSIS

Engine: Deutz TCD 16.0 L V8, 697 hp, 1,950 ft./lbs. of torque at 1,400 rpm

Emission Rating Available; US Tier 4i/EU Stage IIIB/Euro 5 Compliant;

US Tier 3/EU Stage IIIA/Euro 3

Transmission: Allison 4800 EVS transmission; electronic / 7-speed / automatic

Anti-Lock Braking System (ABS)

Cab: 5-person seating max; aluminum frame construction with center steering position; wrap-around, cockpit style instrument panel; easy-read backlit gauges and controls

Transfer Case: Oshkosh® independent with torque proportioning differential and driver selected locking mechanism

Front Axle: 31,000 lbs. (14061 kg); Oshkosh double reduction with bevel gear differential; driver operated differential lock (transverse and separate front to back)

Front Brakes: Drum brakes standard (Rockwell® Dual Actuator Air); optional disc brakes available (17 in. (43 cm) Rotor Bendix® SN7 sliding caliper)

Rear Axles: 31,000 lbs. (14061 kg) per axle; Oshkosh double reduction with bevel gear differential; driver operated differential lock

Rear Brakes: S-cam type; air/drum brake standard, disc brake available

Suspension: Oshkosh TAK-4® independent system with dual control arms and single coil spring; up to 16 in. (40.6 cm) of wheel end travel with superior all-terrain mobility, ride quality and handling

Air Conditioning: 41,300 BTU cooling capacity

Heat: 85,500 BTU heating capacity

Tires: 24R21 all-terrain radial

GVWR: 93,000 lbs. (42184 kg)

Wheelbase: 267 in. (678 cm) from Axle 1 to Axle 3

oshkoshairport.com

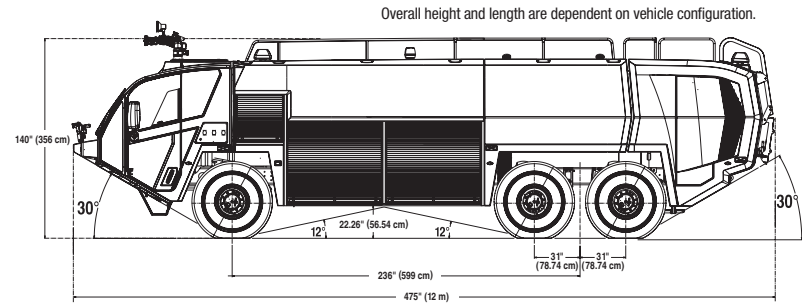

FIREFIGHTING SYSTEM

Roof Turret: Non-aspirating and aspirating options available, electric joystick control; 625/1,250 gpm (2366/4732 lpm), options available up to 1,585 gpm (6000 lpm)

Bumper Turret: Non-aspirating, electric joystick control; 300 gpm (1136 lpm), higher flow options available

Water Tank: 3,000 gal. (11356 l) capacity; corrosion and UV resistant polypropylene

Foam Tank: 420 gal. (1590 l) capacity; corrosion and UV resistant polypropylene

Fire Pump: Power divider driven Waterous® CRQB; single stage centrifugal, cast iron body, brass impeller, stainless steel shaft, pump-and-roll capable; 2,000 gpm (7570 lpm)

Fixed Hose Reels: 100 ft. (30 m) hose length bundled with water/foam or 150 ft. (46 m) hose with dry chemical

Foam Proportioning System Around the Pump

Advanced Firefighting Technology Ready

- Ultra High Pressure Water
- High Pressure Water
- Quad Agent (Water, Foam, Dry Chemical, Clean Agent)
- Compressed Air Foam System

OPTIONS*

Swing Out Hose Reels: 150 ft. (46 m) hose bundled with water/foam or 100 ft. (30 m) water/foam hose with dry chemical

Crosslays: Up to 2 crosslays with up to 300 ft. (91 m) of 1.75 in. (44 mm) hose per crosslay with 2 preconnects (1 each side)

Disc Brakes (outboard mounted)

Mechanical Rear Axle Steering

Central Tire Inflation

Winterization System: For temperatures extreme as -40° F/C

Hydraulic Generator: 10kW or 15kW options

Auxiliary Lighting

High Reach Extendable Turret (HRET)

High Volume, Fixed Mount or Low Attack Bumper Turrets: 1,250 gpm (4732 lpm) capacity

Dry Chemical System: Single agent or dual agent handline and/or primary turret discharge capability

Central Lube System

Hydro-Chem™ Direct Injection: Dry chemical nozzle for primary turret and/or dual agent handline discharge

Clean Agent System: Single agent or dual agent handline, and/or HRET discharge capability

Electronic Foam Proportioning

Waterous CRUQB High Flow Pump: 2,650 gpm (10031 lpm)

Brass/Bronze Pump

Electric Ladder Gantry

Shelving: Roll Out, Fixed, Tilt Down

Ultra High Pressure System

Coil Spring Solid Axle

Fold-Up Doors

Aluminum Skin Tank

Power Doors on Rear Engine Compartment

* Partial options listing only; additional and special request options are also available.

